

Model: SRH-1 Steel 45° Fixed Blade - Flush Surface Mount
 SRH-6 Steel 45° Fixed Blade - Panel - T-Bar Lay-In

SRH-1 - Surface Mount

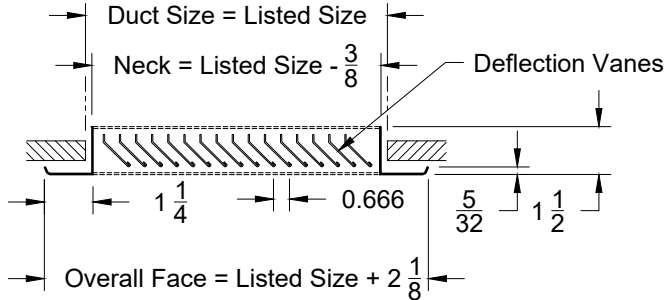

Face View

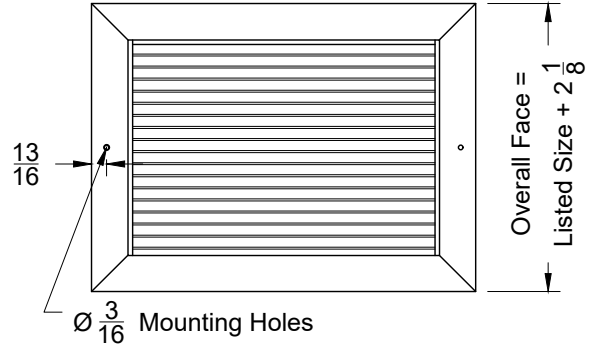

SRH-6 - Lay In T-Bar

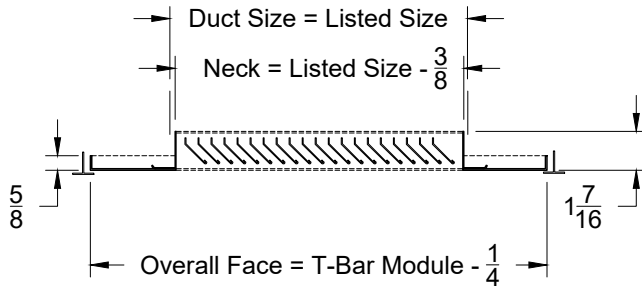

Face View

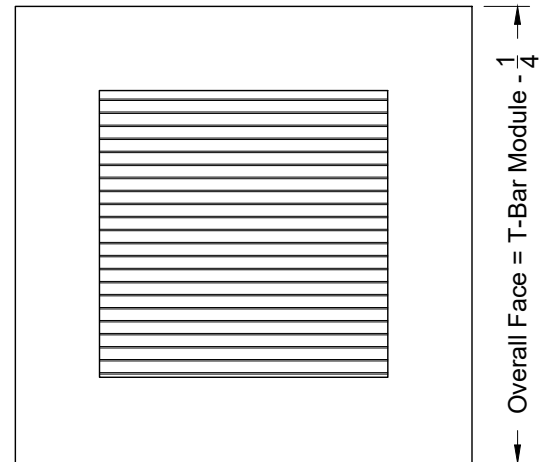

Note: This product complies with NFPA 90A-18 standard 4.3.7.3.2 and 4.3.8.3.2 and is constructed with openings through which a 1/2" sphere can not pass.

1. Available Finishes	2. Available Accessories	3. Available Options	4. Construction Details
Standard Finish: 01 White Finish 24 Mill Finish Optional Finish 02 Satin Silver 03 Black	OBD - Steel Opposed Blade Damper OBDA - Aluminum OBD L9 - Equalizing Grid PF - Plaster Frame TBPF - T-Bar Plaster Frame TR - Square to Round Transition TR-Deep - Deep Transition LIPF - Lay-In Plaster Frame	IS - Insect Screen NSH - No Screw Holes CM - Concealed Mount	<ul style="list-style-type: none"> • Odd/Fractional Sizes Available for additional charge • Oversized Units made in multiple sections • Largest single section is 48x48 • Mullion strips provided for joining units in field
All Dimensions $\pm 1/16"$			

Model: SRH-8 Steel 45° Fixed Blade - Panel - Tegular Module
 SRH-9 Steel 45° Fixed Blade - Bolt Slot / Donn Finline Module

SRH-8 - Tegular Module

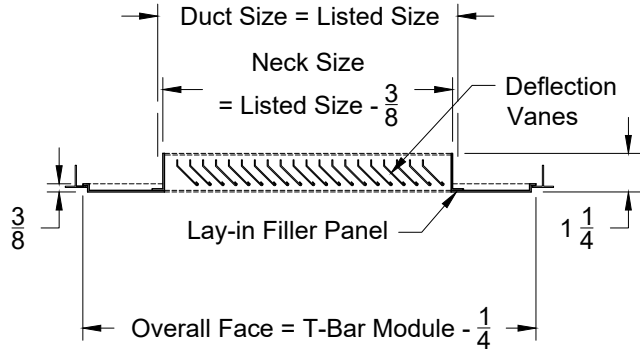

Face View

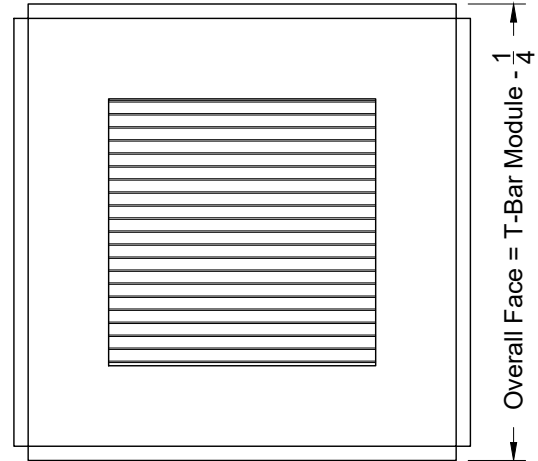

SRH-9 - Bolt Slot / Donn Finline Module

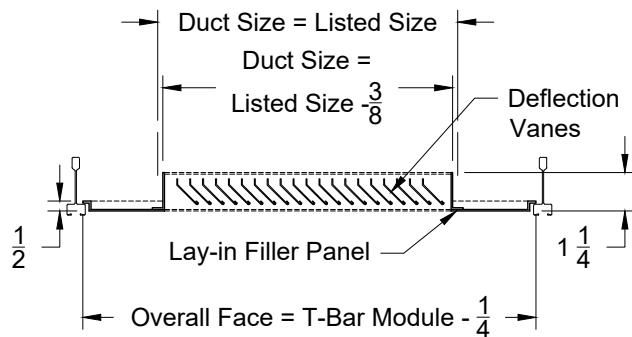

Face View

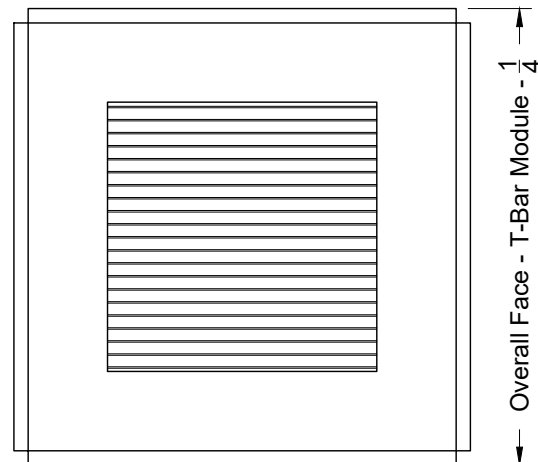

Note: This product complies with NFPA 90A-18 standard 4.3.7.3.2 and 4.3.8.3.2 and is constructed with openings through which a 1/2" sphere can not pass.

1. Available Finishes	2. Available Accessories	3. Available Options	4. Construction Details
Standard Finish: 01 White Finish 24 Mill Finish Optional Finish 02 Satin Silver 03 Black	OBD - Steel Opposed Blade Damper OBDA - Aluminum OBD L9 - Equalizing Grid PF - Plaster Frame TBPF - T-Bar Plaster Frame TR - Square to Round Transition TR-Deep - Deep Transition LIPF - Lay-In Plaster Frame	IS - Insect Screen NSH - No Screw Holes CM - Concealed Mount	<ul style="list-style-type: none"> • Odd/Fractional Sizes Available for additional charge • Oversized Units made in multiple sections • Largest single section is 48x48 • Mullion strips provided for joining units in field
All Dimensions $\pm 1/16"$			

Model: SRH-H-1 Steel 45° Fixed Blade - Surface Mount - Hinged Core
 SRH-H-6 Steel 45° Fixed Blade - T-Bar Lay-In - Hinged Core

SRH-H-1 - Surface Mount - Hinged Core

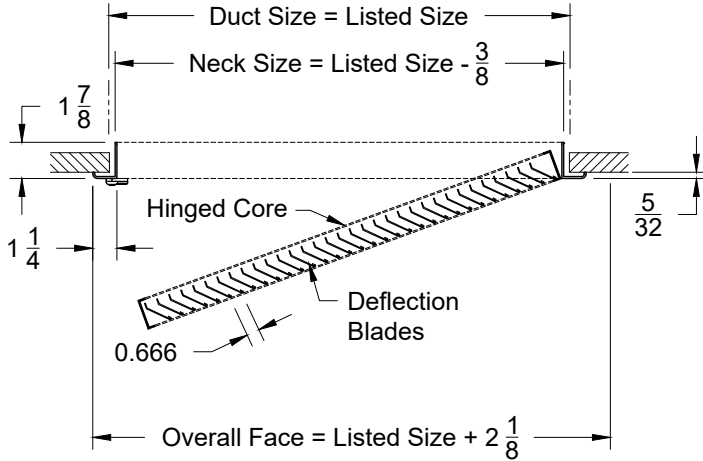

Face View

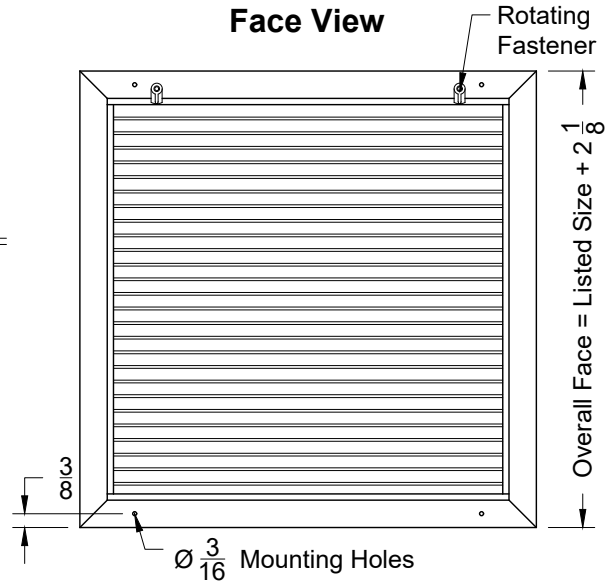

SRH-H-6 - Lay In T-Bar - Hinged Core

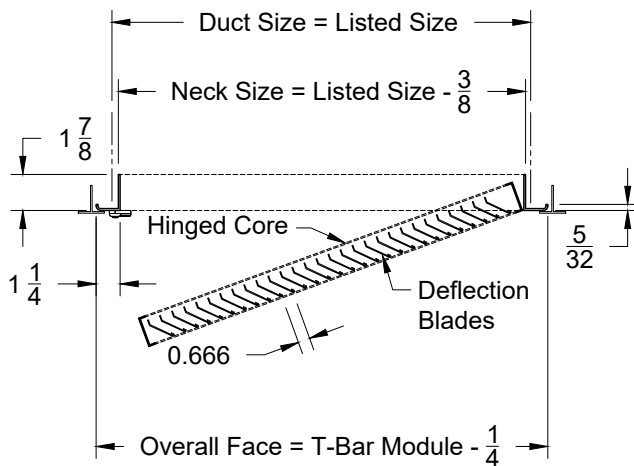

Face View

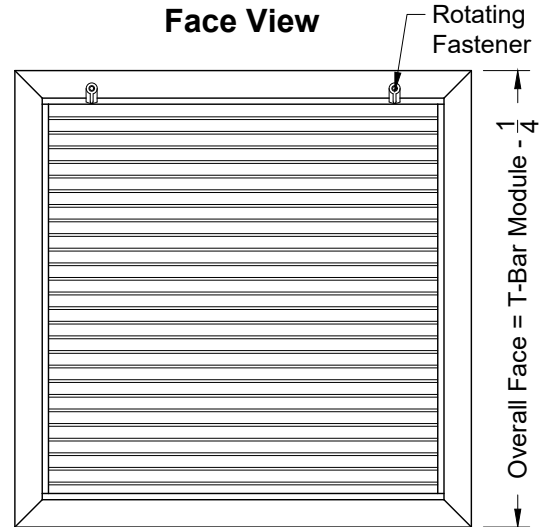

Note: This product complies with NFPA 90A-18 standard 4.3.7.3.2 and 4.3.8.3.2 and is constructed with openings through which a 1/2" sphere can not pass.

1. Available Finishes	2. Available Accessories	3. Available Options	4. Construction Details
Standard Finish: 01 White Finish 24 Mill Finish Optional Finish 02 Satin Silver 03 Black	OBD - Steel Opposed Blade Damper OBDA - Aluminum OBD L9 - Equalizing Grid PF - Plaster Frame TBPF - T-Bar Plaster Frame TR - Square to Round Transition TR-Deep - Deep Transition LIPF - Lay-In Plaster Frame	IS - Insect Screen NSH - No Screw Holes CM - Concealed Mount	<ul style="list-style-type: none"> • Odd/Fractional Sizes Available for additional charge • Oversized Units made in multiple sections • Largest single section is 48x48 • Mullion strips provided for joining units in field
All Dimensions $\pm 1/16"$			

Model: SRH-RC-1 Steel 45° Fixed Blade - Surface Mount - Removable Core
 SRH-RC-6 Steel 45° Fixed Blade - T-Bar - Removable Core

SRH-RC-1 - Surface Mount - Removable Core

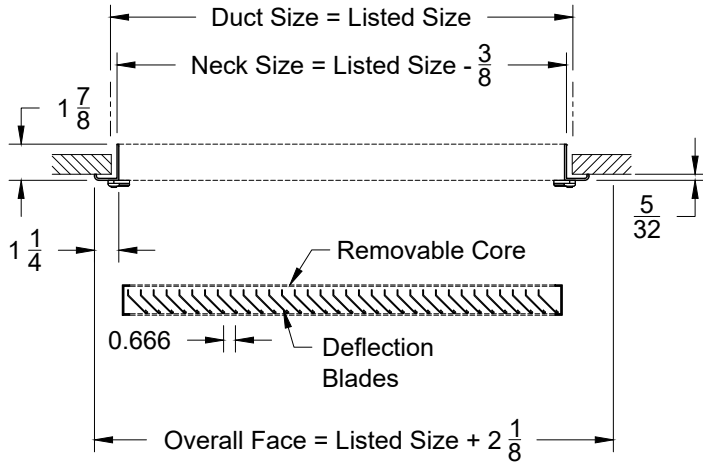

Face View

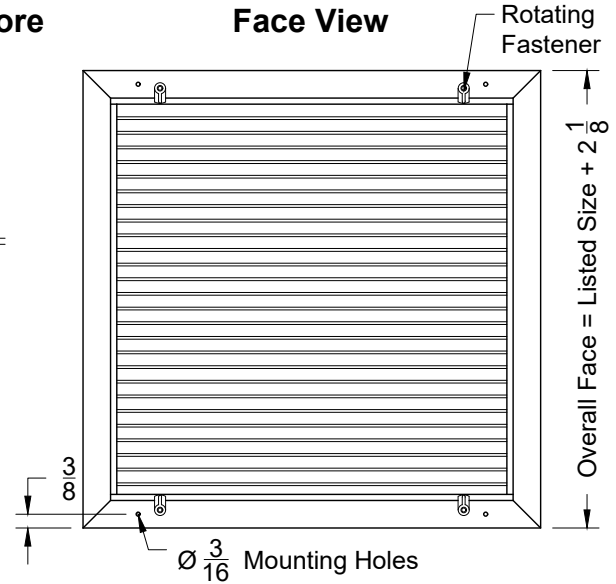

SRH-RC-6 - Lay In T-Bar - Removable Core

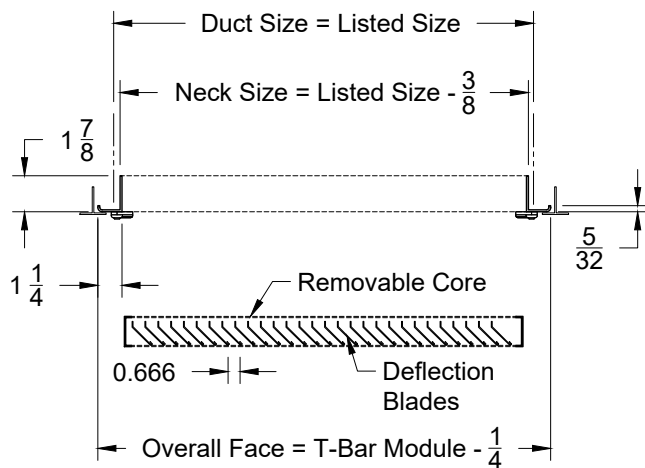

Face View

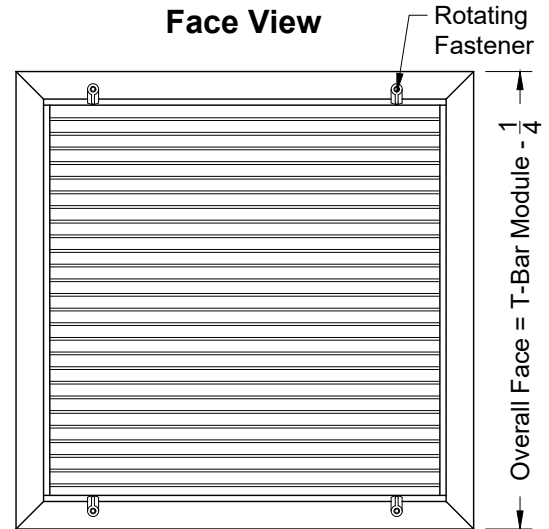

Note: This product complies with NFPA 90A-18 standard 4.3.7.3.2 and 4.3.8.3.2 and is constructed with openings through which a 1/2" sphere can not pass.

1. Available Finishes	2. Available Accessories	3. Available Options	4. Construction Details
Standard Finish: 01 White Finish 24 Mill Finish Optional Finish 02 Satin Silver 03 Black	OBD - Steel Opposed Blade Damper OBDA - Aluminum OBD L9 - Equalizing Grid PF - Plaster Frame TBPF - T-Bar Plaster Frame TR - Square to Round Transition TR-Deep - Deep Transition LIPF - Lay-In Plaster Frame	IS - Insect Screen NSH - No Screw Holes CM - Concealed Mount	<ul style="list-style-type: none"> • Odd/Fractional Sizes Available for additional charge • Oversized Units made in multiple sections • Largest single section is 48x48 • Mullion strips provided for joining units in field

All Dimensions ±1/16"